

USER MANUAL

UOHC3240

UNIFIVE

Motorized Equipment

Industrial Fan · Starter Motor · Conveyor Belt ·
Lift · Automatic Door · Rolling Shutter...

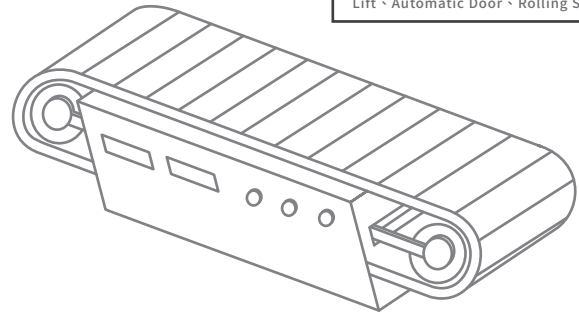

Industrial Printer

Daisy Wheel · Dot-Matrix · Electrostatic ·
Ink-Jet · Laser · Thermal · Line...

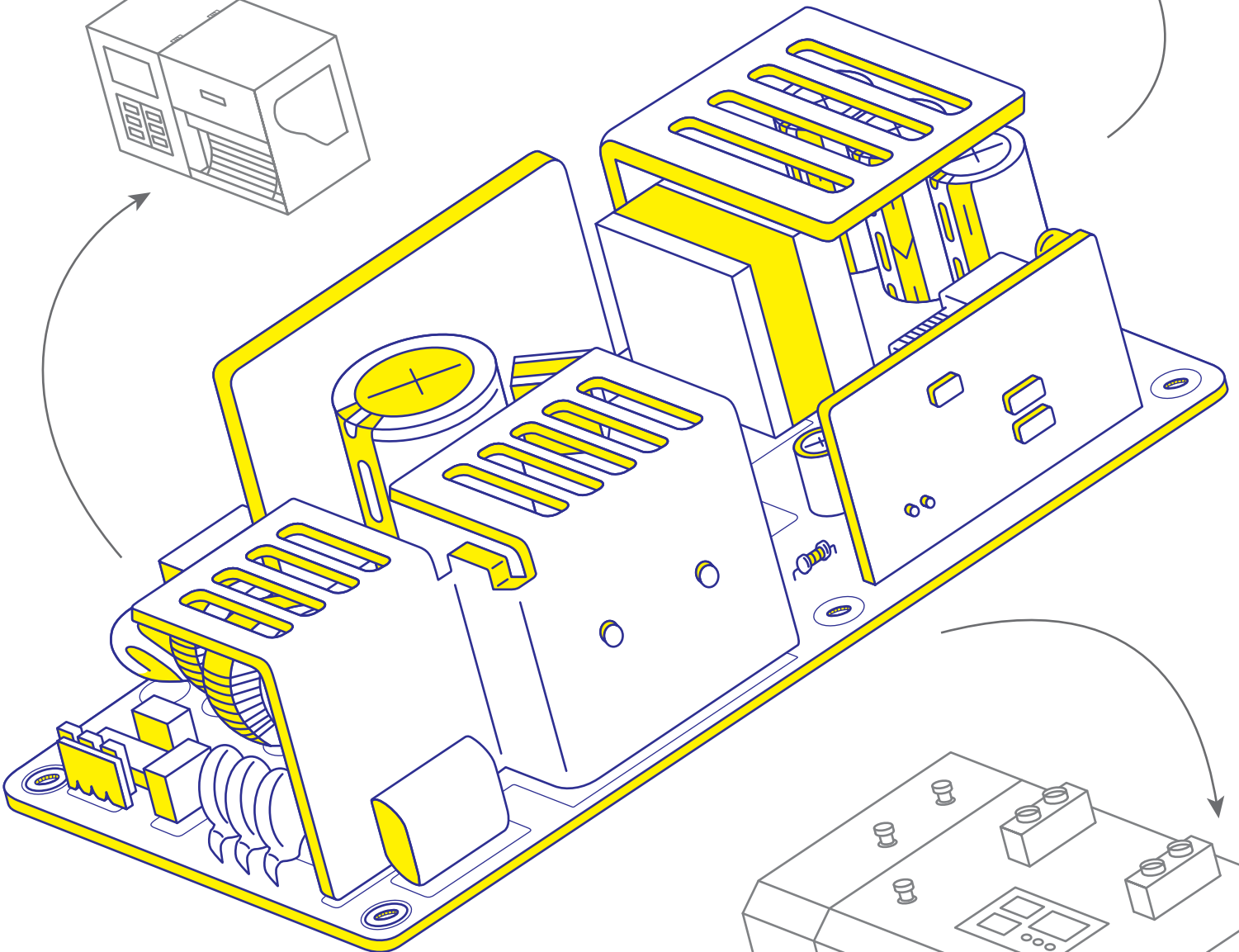
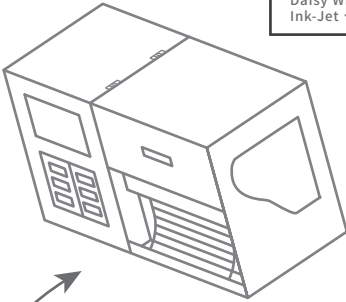

CNC Machine Tool

Machine Tool Fittings , Milling · Lathes · Boring ·
Drilling · Grinding · Engraving machine...

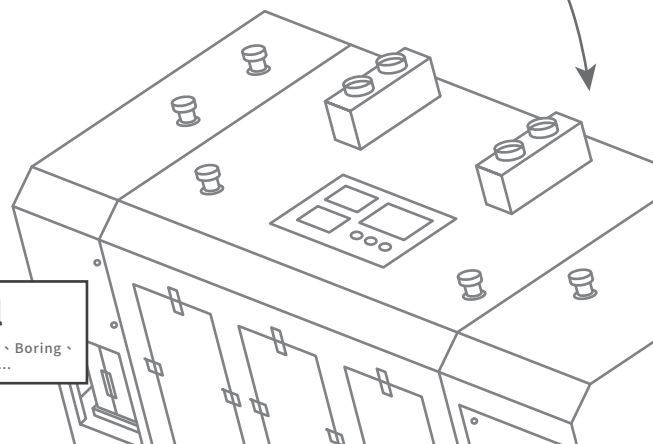

1	Assembling & Installation Method	1 - 3
	1.1 - Installation method	
	1.2 - Mounting Screw	
	1.3 - Ground	
	1.4 - Derating	
	1.5 - Warranty	
2	Peak Load	4
3	Option & Others	5 - 6
	3.1 - Outline of option	

UOHC
AC / DC 240W

1 | Assembling & Installation Method

1.1 - Installation method

- In case of metal chassis, keep the distance between d1,d2 and d3 for to insulate between lead of component and metal chassis, use the spacer of 8mm or more between d1. If it is less that d1,d2 and d3, insert the insulation sheet between power supply and metal chassis.

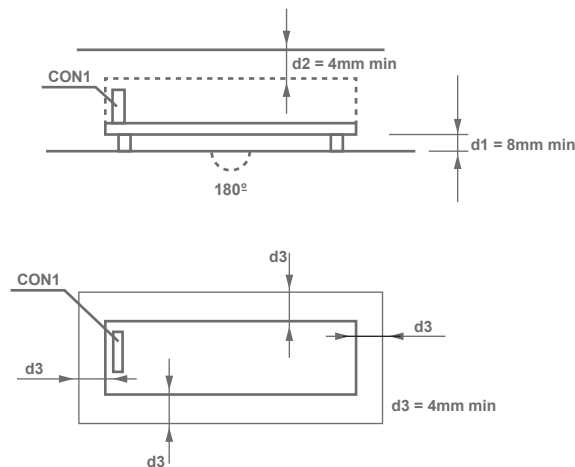
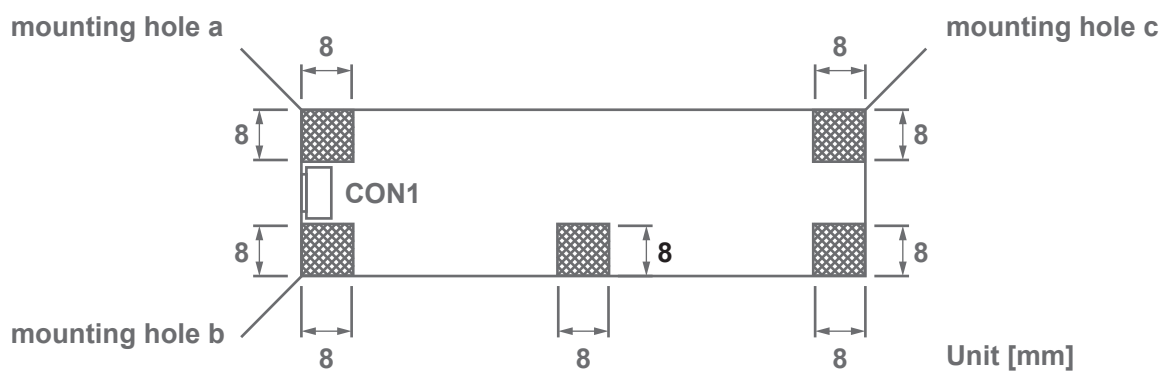

Fig.1.1 Installation method

- Do not twist or bend the printed circuit board since SMD components were soldered on it.

1.2 - Mounting Screw

- Please use M3 screws for mounting.
- It is permitted that the metal parts mounted in the hatched area.
- Mounting holes a,b,c should be connected to safety ground of system unit.



UOHC3240 | Permitted mounting area for metal parts

1.3 - Ground

- Three methods can be used.
 - ① FG pin of CON1 connected to safety ground.
 - ② Mounting holes connected to safety ground.
 - ③ System case connected to safety ground.

1.4 - Derating

- The operative ambient temperature is different by the dimension of user's system or mounting position. Derating curve is shown below.

- The test points of ambient temperature are point A, B and C. The distance between points and power supply is 5cm.

Each point cannot exceed the operating temperature and de-rating conditions may be needed.

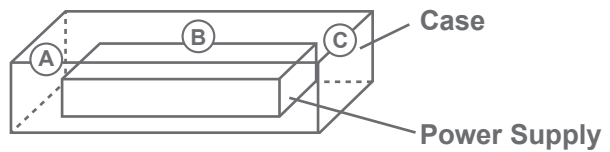

- Mounting Method

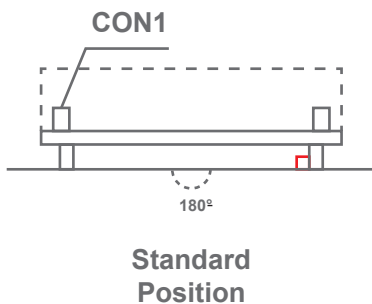

- Derating Curve

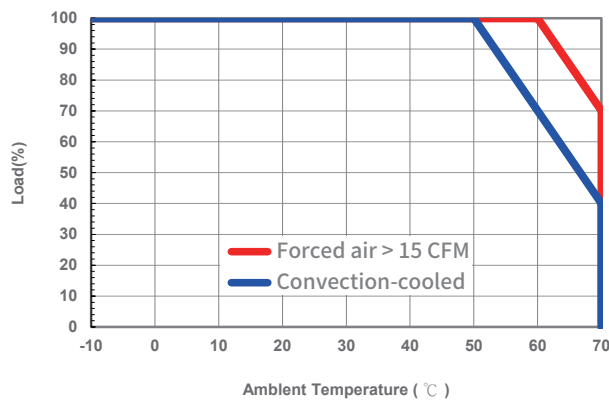

1.5 - Warranty

Cooling Method	Average ambient temperature(year)	Warranty	
		Io ≤ 75%	75% < Io ≤ 100%
Convection	Ta = 40°C or less	5years	5years
	Ta = 50°C	5years	3years
Forced air	Ta = 60°C	5years	3years

2 | Peak Load

- Peak load is possible to draw as below.

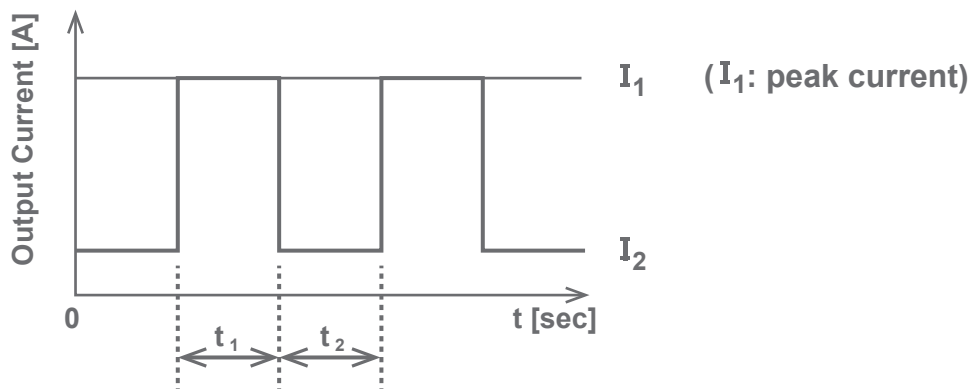

- Peak current I_1 should be lower than 20A and the Duty is less than 0.5

Means that $t_1 \leq 10$ [sec], $Duty = \frac{t_1}{t_1+t_2} \leq 0.5$ $I_1 \leq 20A$

- Average current I_{ave} should be equal or less than rated output current.

$$I_{ave} = \frac{I_1 t_1 + I_2 t_2}{t_1 + t_2} \leq \text{rated output current}$$

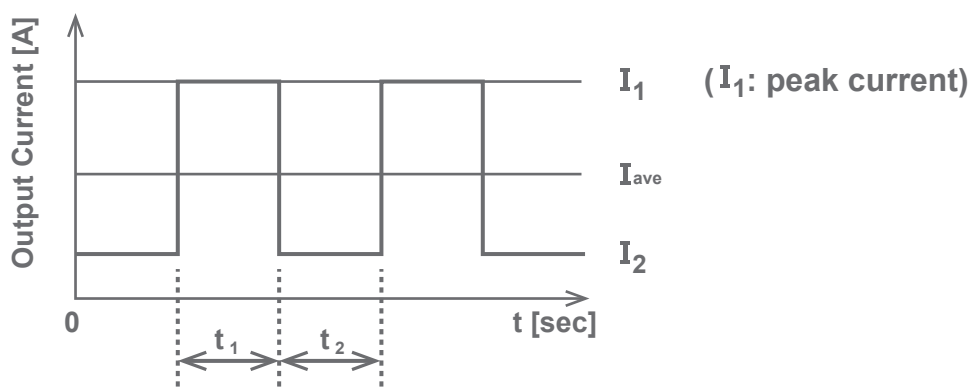

3 | Option and Others

3.1 - Outline of option

- -S indicates a type with additional output 5V.
- -CS indicates a type with chassis and cover.
- -R Control output ON/OFF remotely in Option -R units.
You can use 5V standby power CON106 to supply voltage for controlling output ON/OFF remotely.
An external power supply also can be acceptable.
(see as fig. 3.1 on page6)

———— THE +24V OUTPUT IS TURN ON/OFF BY PS_ON SIGNAL ————

PS_ON	ACTION	LEVEL
LOW	TURN OFF +24V OUTPUT	0V-0.5V
HIGH	TURN ON +24V OUTPUT	4.5V-12.6V

Method
①

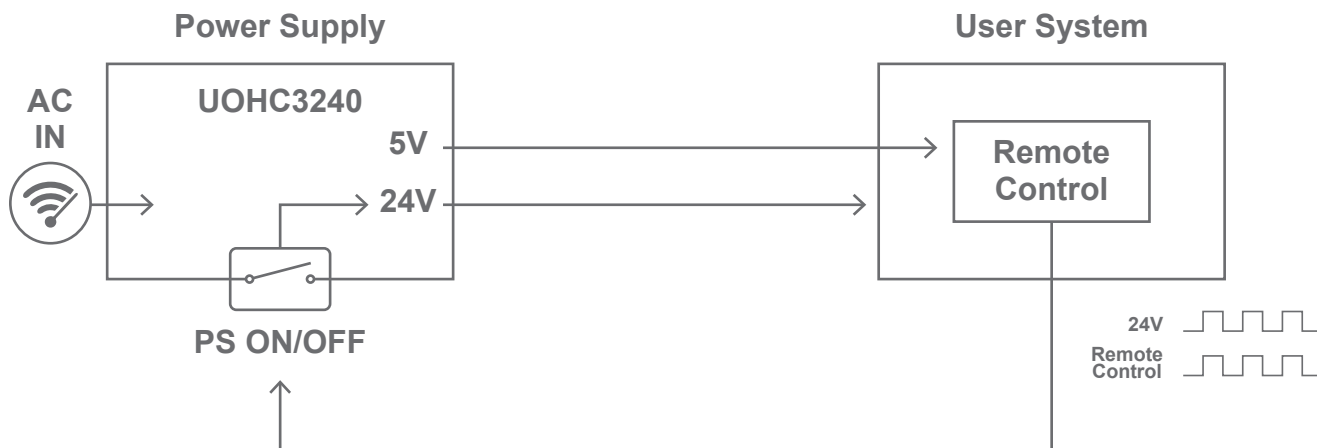

Method
②

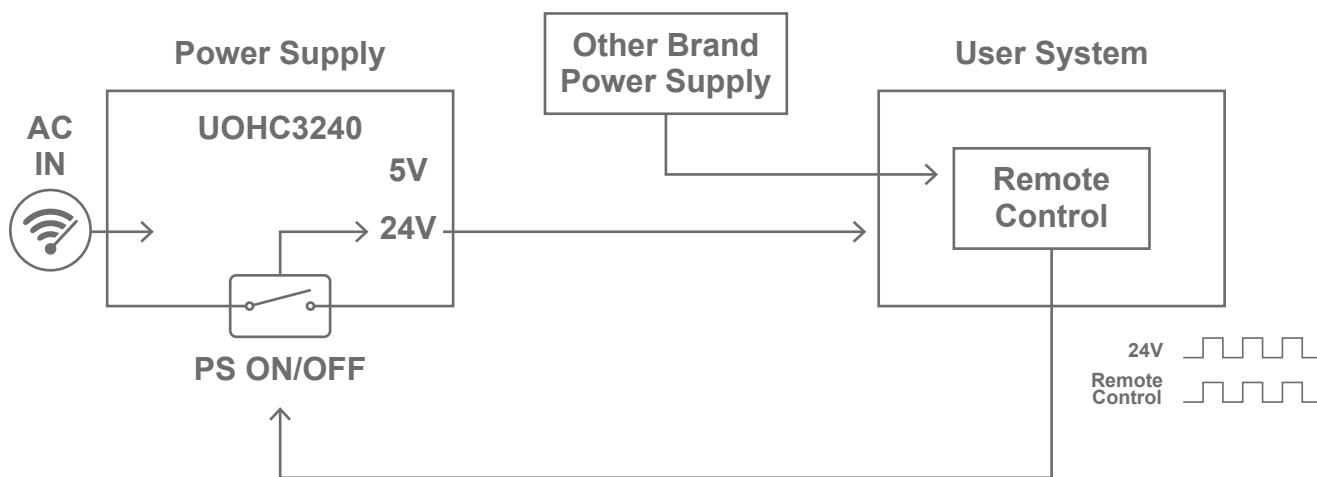

Fig.3.1 Example of using a remote ON/OFF circuit